



Podcast Gear Guide

Evaluating and Using Podcast Gear at Every Budget Level



You can have a great show on terrible gear, and for the most part, it's still a great show. You can have a terrible show on great gear, and it's still terrible. No amount of gear is going to save a terrible show.

– uStudio Podcast on Podcasting

That said, there are a few important pieces of equipment that every podcaster needs, and there are a number of good options out there at different price points. Below is a helpful outline of the items to consider buying, as well as key questions to ask as you decide amongst good, better and best options. Above all else, we recommend purchasing a headphone and microphone for your podcast production.

THE GEAR WE'LL COVER:

	MICROPHONES 02		VIDEO CAMERAS 11
• USB Microphones 02	• Stand-alone Video Cameras 11
• Studio XLR Microphones 02	• USB Webcams 11
• Mobile Microphones 03	• Video Camera Accessories 12
• Camera Mounted Microphones 03	• Video Camera Tripods 12
• Handheld Microphones 03	• Video Camera Monopods 12
• Discreet Microphones 04	• Tabletop Video Camera Tripods 12
• Boom Microphones 04	• Flexible Placement Mounts 12
• Lavalier Microphones 04	• Camera Stabilizers 13
• Microphone Arms And Stands 05	• Miscellaneous Video Accessories 13
• Desk Mounted Microphone Boom Arms 05	• Personal/Studio/Mobile Lighting 13
• Tripod Microphone Boom Stands 05	• Personal Lighting 13
• Handheld Microphone Boom Poles 05	• Studio Lighting 13
• Desktop Portable Tripods 05	• Mobile Lighting 13
• Microphone Accessories 06		MOBILE DEVICE VIDEO 14
• Universal Shock Mounts 06	• Lens Attachments 14
• Mic Clips, Clamps And Shock Clips 06	• Gimbal Phone Stabilizers 14
• Miscellaneous Microphone Accessories 06	• All-in-one Solutions For Smartphones 14
	HEADPHONES 07	• iOS Video Software 14
• Closed-Back Studio Headphones 07	• Android Video Software 14
• Open-Back Studio Headphones 07		VIDEO EDITING 15
	AUDIO MIXERS 08		AUDIO EDITING SOFTWARE 15
	AUDIO INTERFACES 08		HELPFUL AUDIO SOFTWARE 16
	SOUND TREATMENTS 09	• Voice To Text Converters 16
• Personal Space Sound Dampers 09	• Miscellaneous Soundboards, Editors, And Recorders 16
• Room Wall Sound Treatments 09		REMOTE RECORDING SOFTWARE 17
• Free Standing Acoustic / Bass Traps 09		SETTING UP YOUR EQUIPMENT 17
	MOBILE DEVICE AUDIO 10		RECORDING ENVIRONMENT 18
• Hardware Attachments 10		RECORDING YOUR PODCAST 19
• Hardware Mounts 10		EDITING YOUR PODCAST 20
• iOS Audio Software 10	• Editing Audio Podcasts 20
• Android Audio Software 10	• Editing Video Podcasts 21



MICROPHONES

Shopping for a microphone is all about context: what type of shows are you trying to produce and how do you want them to sound? For example, will you be recording in a dedicated, private studio space with good soundproofing? Or recording “man-on-the-street” style podcasts where background noise is a major concern? Will one person be talking on your podcast, or will a number of people be talking more like a radio-style show? How intimate do you need the sound to feel? How you are going to be using the microphone is as important as how much it costs. Here are a some popular options for most needs. **Remember: you'll need one microphone per speaker.**

USB MICROPHONES

USB microphones are the easiest way to capture your podcast dialog and voice-overs. The easy plug-and-play functionality allows you to get set-up and recording within minutes. They require less connections and equipment than traditional XLR microphones.

Rode NT-USB-Mini USB Microphone

\$100

This high-quality condenser capsule delivers professional sound. The built-in pop filter reduces plosives while the cardioid pickup pattern is optimized to reduce noise and smooth frequency response. This is a great entry-level, studio-quality microphone with USB-C connectivity and 3.5mm headphone output with zero-latency monitoring.



Blue Yeti USB Microphone

\$130

The Blue Yeti is a popular mic within the podcasting community and its sound quality is well-reviewed. It's a USB condenser mic, so it is able to pick up a greater depth of sound. It can be connected right into your computer. As a bonus, this mic comes with its own sleek stand, giving you one less thing to worry about.



Shure MV7 Cardioid Dynamic Microphone

\$250

Inspired by the legendary SM7B, the MV7 is a dynamic microphone with both USB and XLR outputs for use with computers and professional interfaces alike. Connect via USB to use Auto Level Mode, which helps you control your vocal tone and distance from the microphone. With Auto Level Mode, you can let the microphone do the work for you.



STUDIO XLR MICROPHONES

Condenser and cardioid dynamic microphones are the industry standard for clear warm audio recordings, and can be used in most podcast situations. You'll need a mixer or multi-input audio interface to use these microphones.

AKG P120 Project Studio Condenser Microphone

\$100

This true condenser microphone offers solid build quality, outstanding performance and excellent value. The low-mass diaphragm delivers clear sound with accurate sonic detail for voice recording in any studio. The rugged body design withstands tough day-to-day use and the switchable bass-cut filter eliminates rumble and noise.



Rode PROCASTER Dynamic Microphone

\$230

Procaster is a broadcast-quality dynamic mic which offers uncompromising performance for voice applications in a broadcast environment. Featuring a tight polar pattern tailored to voice frequency response, the Procaster is great for every application where a great-sounding, rugged microphone with great ambient noise rejection is needed.



Shure SM7B Cardioid Dynamic Microphone

\$400

This is our mic of choice here at uStudio. It's a broadcast-quality mic that delivers an intimate sound with incredibly rich and deep audio. This is a professional grade mic so pricing runs about \$400 per unit. If you have the technique, budget, and studio, this mic is very popular with the pros.





MOBILE MICROPHONES

Man-on-the-street style podcasting can require specialized mobile microphones to capture audio in noisy open-air conditions. In some situations the mic included in your video camera is just fine, but for very loud situations you'll want to opt for a directional mic that focuses its audio sensor towards one specific location—your subject. Adding a windscreen to your mic can dramatically reduce the amount of environmental noise in mobile outdoor situations.

CAMERA MOUNTED MICROPHONES

Enjoy improved sound quality at greater distances by adding a professional grade shotgun mic to your rig with the following mountable options. Be sure to check your camera to make sure they'll work for you as some video cameras have proprietary connections that may not support 3.5mm audio input.

Rode VideoMic GO On-Camera Microphone

\$60

Compact and light-weight, this mic delivers clear, crisp, directional audio. Its tight pickup area ensures that your subject is isolated from distracting background noise.



Sennheiser MKE 400 On-Camera Microphone

\$200

This microphone sports an integrated shockmount which conveniently stands the MKE 400 onto any camera accessory shoe. It effectively suppresses and handles all vibration noise.



Rode VideoMic Pro Plus On-Camera Microphone

\$300

This best-in-class suspension system improves on the existing VideoMic Pro capsule/line tube and windshield, plus boasts a host of features to make your audio shine.



HANDHELD MICROPHONES

Get up close and personal with these handheld interview-style mics. Any handheld mic can work, but if you want to mimic the newscaster look, turn your attention to these stylish microphones. There are not huge differences between these mics, so use the quality-to-price formula when choosing. You may need a XLR adapter for these mics depending on your camera.

Movo HM-M2 Dynamic Interview Microphone

\$50

This professional quality microphone is specifically designed to capture voice and speech with remarkable sensitivity and accuracy. It is designed to reduce post-production editing time.



Electro-Voice 635L Interview Microphone

\$150

This live interview microphone comes with an omnidirectional polar pattern. This prevents the user from sounding "off mic," and works to eliminate plosives and other proximity effects using its built-in shockmount and pop filter.



Sennheiser MD 46 Cardioid Interview Microphone

\$200

The MD 46 has a traditional long handle, wind attenuation and off-axis rejection. It is designed to possess an extended high-frequency response, warm lows, and a clean midrange.





DISCREET MICROPHONES

Elephant in the room? Depending on what style video podcast you're recording, you might not want visible technology in your shots. Boom or lavalier mics are discreet solutions in this case.

BOOM MICROPHONES

Keep the microphones totally out of the shot with the use of boom mics. Point these directional mics towards your subject like they do on your favorite TV show. As usual, you'll need one mic per person for sound optimization.

Audio-Technica ATR6550 Boom Microphone

\$70

Crisp & intelligible pickup—far away or up close. Pick up dialogue and sound effects at a distance, while bypassing ambient noise such as traffic or room noise.



Audio-Technica AT875R Boom Microphone

\$170

This high-performance microphone offers a narrow audio acceptance angle. It produces smooth, natural-sounding quality and excellent rejection of rear and side noise.



Sennheiser MKE 600 Boom Microphone

\$330

This mic provides maximal rejection of side noise thanks to its pronounced directivity. Its "low cut" filter minimizes wind noise and is very good for suppression of structure-borne noise.



LAVALIER MICROPHONES

These mics are still visible on video, but greatly reduce the visual clutter and proximity issues associated with other mic solutions. Use these when you need up-close sound for each participant. As seen on your local news or interview shows, these mics tend to have limited frequency range suited for picking up the human voice.

NOTE: You'll need a body pack transmitter to use these mics.

Line 6 LM4-T Lavalier Microphone

\$65

This condenser microphone features a cardioid polar pattern and TA4-F connection for use with the Line 6 TBP12 wireless bodypack transmitter. Includes a microphone clip and delivers hands-free speech for podcasts.



Rode SmartLav+ Lavalier Microphone

\$95

The smartLav+'s small size and built-in cable management makes it ideal for on-camera interviews where it can be worn discreetly while still picking up everything your subject says.



Shure SM11 Lavalier Microphone

\$160

A miniature dynamic lavalier microphone designed for use in television broadcasting and sound reinforcement where a small, professional-quality, microphone is required.





MICROPHONE ARMS AND STANDS

Make life easier in the studio, on the street, or in your hotel room with an extra pair of 'hands'. Check out the following mic arms, stands and poles to see what you may need for your setup.

DESK MOUNTED MICROPHONE BOOM ARMS

Microphone boom arms are great for audio podcasts or radio-style video podcasts. The flexible positioning and ability to swing these out-of-the-way when you're done recording will make pod life a breeze.

**Knox Boom
Microphone Arm**
\$50



**Blue Compass
Broadcast Boom Arm**
\$100



**VIVO Black Pneumatic
Spring Microphone Arm**
\$70



**K&M 23860
Microphone Desk Arm**
\$280



TRIPOD MICROPHONE BOOM STANDS

A staple on-scene or in the studio, the common tripod boom stand is a must for many production styles. Great for off-screen directional mics and overhead sound capture—odds are you'll need some.

**Pyle Foldable
Mic Boom stand**
\$20



**K&M 21120
Mic Boom stand**
\$40



**Gator ID Series
Mic Boom Stand**
\$100



HANDHELD MICROPHONE BOOM POLES

When you have limited microphones or don't want mics on-camera during mobile shoots, reach for a handheld boom arm. You need an extra person to wield these but they are very effective for remote shoots.

**On-Stage MBP7000
Boom Pole**
\$56



**LyxPro MPL-20
Pro Boom Pole**
\$90



**Rode Professional
Boom Pole**
\$120



DESKTOP PORTABLE TRIPODS

These are a simple solution for your desk or for when you're podcasting from a hotel room. Fold-and-go mini tripods will get the job done at low cost and are a great solution for a panel of guests or seminar-style podcasting.

**Neewer Universal
Desktop Tripod**
\$9



**Ammoons MS-12
Mini Tripod**
\$10



**Antopy Foldable
Desktop Stand**
\$12





MICROPHONE ACCESSORIES

There are tons of accessories for microphones ranging from tools and fasteners to final cosmetic touches. Here are some accessories to consider for your podcasting efforts.

UNIVERSAL SHOCK MOUNTS

Eliminate floor noise and stand rumble by using shock mounts to suspend and isolate your studio microphones. Most studio mics come with shock mounts designed for their specific form-factor, and some ship without any at all. These universal shock mounts may work for your needs.

LyxPro MKS1-B – \$25



Audio-Technica AT8415 – \$60



Rycote 44901 Invision – \$80



MIC CLIPS, CLAMPS AND SHOCK CLIPS

If you're in the podcasting business, you'll need plenty of clips, clamps, and other accessories to make your shoot a breeze. Butterfly mic clips handle any handheld mic. Shock clips add shock mount functionality to handheld mics and mic clamps allow you to put mics anywhere you wish.

On-Stage MY200 Clip – \$6



Bestshoot Shock Clip – \$8



Meinuoke Mic Clamp – \$17



MISCELLANEOUS MICROPHONE ACCESSORIES

Don't forget the cables!!! The following accessories can enhance your shoot and make podcasting easier.

AmazonBasics XLR Male to Female Cable – \$8 and up

Make sure you have enough XLR cables for your studio or mobile setup.



Aokeo Professional Pop Filter – \$10 and up

Plosives can ruin your audio—get them under control with a pop filter.



On-Stage Foam Ball-Type Windscreen – \$3 and up

Cut the wind and a few plosives that happen while using handheld microphones.



Devinal Balanced XLR to 1/8 Female Adapter – \$10 and up

Attached a handheld XLR mic to your video camera with this XLR to 3.5mm adapter.



Casematix Travel Case – \$40 and up

Protect and organize your gear with a padded carrying case for ease of travel.



Rycote 107301 Microphone Flag – \$20 and up

Apply your logo to this mic flag so it's always present in your video productions.





HEADPHONES

Whether you're in an office, studio, or on the road, you'll need a good set of headphones (or perhaps two). Use closed-back headphones while recording audio to eliminate speaker bleed and feedback. Although you can use these while editing, we recommend open-back headphones for a non-colored true representation of your audio. Be sure to get studio quality headphones and not consumer grade as they often have electronics that color the sound with frequency curves.

CLOSED-BACK STUDIO HEADPHONES

Use studio headphones instead of audio monitors while recording to eliminate feedback. Great for radio style podcasts and for personal messages.

Audio-Technica ATH-M20x Closed-Back Headphones \$50

The ATH-M20x professional monitor headphones are a great introduction to studio headphones. The combination of its modern design and high-quality materials deliver a comfortable listening experience with enhanced audio and effective isolation. This is an excellent choice for tracking podcast audio sources.



Sennheiser HD280PRO Closed-Back Headphones \$100

This closed, around-the-ear headphone is designed to exceed the demands of the professional environment. Its extremely robust construction combined with the sound quality, modular design, and aggressive noise isolation is necessary in the audio recording field. In studio or on location, you can't go wrong with these.



Beyerdynamic DT 770 PRO Closed-Back Headphones \$230

Professional users all over the world have placed their trust in the classic 770/880/990 PRO range of headphones. They boast extremely detailed resolution and very transparent sound. They are particularly appealing to professionals owing to their bass reference capabilities and spacious reproduction that is absolutely remarkable.



OPEN-BACK STUDIO HEADPHONES

In most cases, you can use closed-back headphones while editing. However, if your podcast application needs to have precise audio representation we recommend reaching for one of these headphones instead.

Grado SR80e Open-Back Stereo Headphones \$100

The sr80 provides improved bass resonance which enhances the overall detail of your audio referencing. Features include a vented diaphragm, no resonant air chamber, standard copper voice coil wire, standard copper connecting cord, and a mini plug with 1/4" adaptor. This is a great entry-level product from Grado Labs.



Beyerdynamic DT 990 Pro Open-Back Headphones \$135

The Beyerdynamic DT 990 PRO headphones are a loyal companion for podcasters due to its wide stereo image and three-dimensional sound reproduction. Outstanding tonal depth ensures that even small changes in the positioning of the acoustic source can be perceived while mixing.



Audio-Technica ATH-R70x Open-Back Headphones \$250

These headphones include high-efficiency magnets and a pure alloy magnetic design that reduces distortion and ensures high-frequency response. The carbon composite resin improves structural rigidity to provide a detailed transient response. Its aluminum honeycomb-mesh housings produce natural transparent sound.





AUDIO MIXERS

If you're running a radio or multi-speaker type show you'll most likely need a mixer. Mixers allow you to combine audio signals from each participants' microphone and blend them together into one or multiple audio streams for capture. The following mixers can be use as stand-alone or connected to your computer via USB.

Behringer Xenyx Q802USB Mixer with USB

\$120

The trend towards mixers with onboard audio interfaces has been well noted. This compact, value-packed mixer comes with 8-inputs, Xenyx mic preamps and compressions, Behringer's "British" 3-band EQ, and a USB interface. High-quality components and rugged construction ensures long life.



Mackie ProFX12v2 12-channel Mixer with USB

\$280

With all the right features for the job, the ProFX12v2 allows you to create memorable podcasts. Portability is paramount and you don't want to be burdened with lugging around additional equipment. Thankfully, integrated USB I/O takes the pain out of recording. Just connect the USB cable to a laptop and start recording!



PreSonus StudioLive AR12 Mixer with USB

\$600

A great podcast is one you'll want to preserve. Fortunately, the compact StudioLive AR12 USB from PreSonus makes it easy to capture multitrack audio. You can send all channels to dedicated tracks in your editor for later mixdown, or stream instantly to your colleagues with a stereo mix of the show.



AUDIO INTERFACES

If you don't mind mixing your audio on a computer, audio interfaces are the way to go. With an audio interface, you will have access to 1-8+ microphone inputs and the ability to capture and mix in your audio workstation of choice. These can be more compact than mixers, and a great solution for studio or mobile usage.

PreSonus AudioBox iTwo USB Audio Interface

\$160

The PreSonus AudioBox iTwo USB audio interface is an outstanding solution for two-channel recording applications. With two Class A mic/instrument preamps and 24-bit/96kHz recording quality, you're well equipped for stereo recordings or capturing two microphones at once.



Audient iD4 USB Audio Interface

\$200

Packing large-format console performance into a petite desktop chassis, the Audient iD4 audio interface fortifies your studio. With Class A console mic preamps, a discrete JFET DI, class-leading conversion technology, two headphone jacks, and a console-style monitoring control, the Audient iD4 is a serious tool for any studio or mobile rig.



M-Audio M-Track 8X4M USB Audio Interface

\$300

Skip the mixer—the M-Track 8X4M gives you eight channels of 24-bit/192kHz-quality audio and four TRS ins for flexible monitoring and routing. The M-Track 8X4M's desk-friendly form puts all essential controls right at your fingertips, with an ergonomic tilt that improves visibility for desktop and remote use.





SOUND TREATMENTS

Hard reflective surfaces, like walls and glass, can wreak havoc on your audio recordings by adding hollow-sounding room reverb. You can get reflections under control and record professional sounding audio in no time with sound treatments for your space. Check out our recommendations for acoustic control devices.

PERSONAL SPACE SOUND DAMPERS

Sometimes you won't have the ability to install full-room sound treatments for recording or editing purposes. Try reaching for one of these personal sound control devices.

sE Electronics Reflexion Filter X Portable Vocal Booth

\$100

Acoustic filter technology at an affordable price. Materials are lightweight yet rugged enough to stand up to the most demanding work environments.



sE Electronics Reflexion Filter PRO Portable Vocal Booth

\$200

This device is an elegant and simple way to improve the sound of your acoustic space and includes six different layers to diffuse the sound waves around the mic. You'll want this on your favorite mic!



ROOM WALL SOUND TREATMENTS

Auralex Studiofoam DST-114 Acoustic Panel 24-pack

\$140

These 1-foot x 1-foot panels provide true Studiofoam absorption at a reasonable price.



Auralex 2" Studiofoam Metro 2'x4' Acoustic Panel 12-pack

\$510

Studiofoam Metro uses skyline-style protrusions to spread sonic energy into the room.

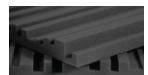

Auralex ProPanel ProKit-1 Room Treatment System

\$1,530

This kit eliminates room reflections, flutter echoes, standing waves, and other room issues.

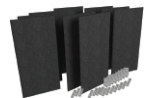

FREE STANDING ACOUSTIC / BASS TRAPS

Primacoustic GoTrap Studio

\$400

GoTrap controls high-end reflections while soaking up excessive bass in the room.





MOBILE DEVICE AUDIO

Current mobile devices offer some outstanding features for creating audio podcasts. Here are some hardware and software tools that'll get your message across with no fuss.

HARDWARE ATTACHEMENTS

For most cases you can use the built-in mic on your smart device, but if you want to take your audio recordings to the next level of quality, then consider one of these fine add-ons.

Zoom iQ7 Mic iOS Lightning \$100

Capture detailed, lifelike audio in your iOS apps.



Shure MV88 Mic iOS Lightning \$150

Clean clear recordings even in noisy locations.



Rode iXY-L Mic iOS Lightning \$200

Instantly transform your iOS device into a recorder.



Pyle XLR-to-USB USB \$40

Connect any XLR mic to your USB mobile devices.



SmartRig+ USB-C \$180

Record two XLR mics directly into your device.



iRig PRO DUO 2 Lightning/USB \$200

Record two XLR mics with stellar audio quality.



HARDWARE MOUNTS

Make mobile podcasting easier with a second pair of hands. Here are a few suggestions that you may want to add to your phone or tablet rig.

Lamicall Gooseneck Desktop mount \$16

A flexible arm can help get the perfect shot.



iKlip Grip 4-in-1 Holder \$50

Selfie-stick, tripod, monopod, & stabilizer.



iOrbit Triad Clamp Holder \$108

Clamp your device anywhere and shoot.



iOS AUDIO SOFTWARE

There are a plethora of audio app offerings on the Apple App Store. Here are some recording options from simple record and edit to advanced multitrack recording. Don't let the thought of editing software scare you. Our friends at [LivePerson](#) were able to easily teach themselves editing basics on Garageband through a few short YouTube tutorials.

Voice Memos
Simple Recorder \$0

Voice Recorder
Simple Recorder \$4

GarageBand
Multitrack \$0

Take
Multitrack \$0

ANDROID AUDIO SOFTWARE

The Google Play store has many audio apps you can use in your podcasting efforts. Here are some recording options from simple record and edit to advanced multitrack recording.

Samsung Voice Recorder
Simple Recorder \$0

Easy Voice Recorder Pro
Simple Recorder \$4

n-Track Studio Music DAW
Multitrack \$0

FL Studio Mobile
Multitrack \$15



VIDEO CAMERAS

Video podcasting can improve information retention as some people learn best by visual example, verbal cues, and body language. There are many options when it comes to video cameras on the market. Determine your application: are your podcasts going to be ephemeral timely updates, or will they be curated for long-term consumption? You may also need more than one camera depending on if you're producing a show that involves single or multiple subjects.

STAND-ALONE VIDEO CAMERAS

If you're looking to curate content you'll want to get the best camera your budget can afford. Like audio, video quality is one of the most important technical aspects of video podcasting. For this application you'll want a camera that supports 1080p and/or 4k. This will help ensure your content format will be viable for years to come. The following can all be stand-alone for when you don't want to be tethered to a computer, or can be used as a super high-quality direct-to-computer webcam depending on your podcast style. Here are a few choices to get you started.

GoPro Hero 7 Video Camera

\$185

Built to handle whatever you throw at it, GoPro has become the go-to camera for mobile action shots as well as being a stellar studio podcasting camera. If you need multiple cameras, these are relatively cost-effective while capturing high-quality video. Records 4K30, 1440p60, and 1080p60 video.



Sony FDR-X3000 Action Video Camera

\$400

Incorporating optical image stabilization and 4K recording, this camera produces sharp video with reduced motion artifacts from vibrations and other movements. The ultra-wide angle lens opens up versatile framing options for recording mobile or studio shots. Supports 4K, 1080p, 720p, 480p video and Wi-Fi remote monitoring and control.



Canon EOS Rebel T7 Video Camera

\$600

The T7 produces high-resolution video with notable clarity and reduced noise. With its superior sensor, processor, and lens, this camera will bring your video podcast to life. The optical viewfinder and 9-point auto-focus system increases accuracy and focusing speed to dial-in your subject. Supports 1080p, 720p, 480p video and Wi-Fi transfer.



USB WEBCAMS

If your podcasting needs are geared more towards temporary or timely information distribution, you'll probably be best served by using the built-in camera on your computer, or upgrading to a higher quality aftermarket webcam. These cameras are suited for recording personalized messages to disseminate to your team. USB cameras are somewhat limited; if your needs include mobility or multiple subject matters, you'll be better off investing in the stand-alone cameras. Here are some USB cameras that can improve your video quality beyond what's built into a computer.

Logitech Pro Webcam

\$135

This 1080p HD webcam supports H.264 with Scalable Video Coding and UVC 1.5 encoding technology. By putting video processing within the camera, it is able to adjust dynamically to the available bitstream and enable more PC bandwidth. The result is a smoother video stream in applications. It is perfect for product demos and podcasting.



Zoom Q2n-4K Handy Video Recorder

\$200

The Zoom Q2n-4K Handy Video Recorder pairs high-resolution UHD 4K video capture with up to 24-bit/96 kHz audio recording. Five field-of-view settings and one-button recording enable you to easily capture yourself and/or your teammates. The high dynamic range enables you to get correctly exposed shots, keeping your subject lit properly.



Mevo Plus 12.4 MP Ultra HD Camcorder

\$500

This is the advanced camera from Livestream, re-engineered for faster and stronger performance. With this camera you can transform any event into a professional live production as well as edit video in real-time and stream live to company employees. Enable Autopilot and let Mevo's advanced AI do the editing for you.





VIDEO CAMERA ACCESSORIES

There are endless accessories to support the video industry. You can drastically improve your shoots by adding key pieces to your personal, studio, or mobile podcasting rig. This includes stands, mounts, stabilizers, cases, adapters, storage media and lighting.

VIDEO CAMERA TRIPODS

A staple on-scene or in the studio, the common tripod boom stand is a must for many production styles. These are great for off-screen directional mics and overhead sound capture. Odds are you'll need a tripod.

Neewer Aluminum Camera Tripod
\$35



Sturdy Tiger Pro Tripod & Monopod
\$75



Digiant Heavy Duty Twin Tube Tripod
\$130



VIDEO CAMERA MONOPODS

When you need a steady shot but don't have the time to set up a tripod, use a monopod instead. Just plant these on the ground and shoot and you'll be off to the next location without any additional steps.

Manfrotto Element Aluminum Monopod
\$40



Manfrotto 290 Carbon Fiber Monopod
\$92



IFOOTAGE Carbon Fiber Monopod
\$180



TABLETOP VIDEO CAMERA TRIPODS

When you have limited microphones or don't want mics on-camera during mobile shoots, reach for a handheld boom arm. You'll need an extra person to wield these but they are very effective for remote shoots.

Qubo Mini Tabletop Tripod
\$22



Bestshoot Mini Tabletop Tripod
\$31



ZOMEI Mini Tabletop Tripod
\$41



FLEXIBLE PLACEMENT MOUNTS

These fold-and-go mini tripods are a great solution for podcasting at your desk or hotel room, or when you are hosting a panel of podcasters. They are guaranteed to get the job done at a low cost.

D&F Jaws Flex Clamp Mount
\$11



Fat Gecko Suction Cup Mount
\$28



JOBY GorillaPod Flexible Mount
\$70





CAMERA STABILIZERS

Cut down on shaky mobile shots with a gimbal style stabilizer. Although some cameras and video software 'fix' movements with processing algorithms, this can create video artifacts. It's better to stop it at the source with a stabilizer. Check your camera's mounting option before buying.

REMOVU S1 for GoPro

Handheld gimbal stabilizer
\$200

Zhiyun-Tech CRANE-M2

Handheld gimbal stabilizer
\$270

Moza Air 2

Handheld gimbal stabilizer
\$600



MISCELLANEOUS VIDEO ACCESSORIES

Sometimes you need minor items to support your video efforts. Here are a few to consider.

UURig R003 Universal Pistol Grip

Handheld stabilizer or microphone mount
\$6



Teradek 11-0053 Teradek Case

Customizable foam-lined road case
\$100



Sennheiser KA600i XLR to 3.5 mm

XLR to camera or smartphone adapter
\$20



Saramonic SR-AX101 Audio Adapter

Universal audio adapter with dual XLR inputs
\$60



Storage Media (SD or external drive)

Don't forget you'll need storage per camera spec
\$6 and up



Gaffers Tape

You'll need temporary tape... enough said
\$14



PERSONAL/STUDIO/MOBILE LIGHTING

There are many lighting solutions for every budget, ranging from personal ring lights, to full room lighting and mobile solutions. Choosing lights that emulate sunlight can drastically improve your video quality, make your videos warm and pleasant, and ensure your subject is fully lit.

PERSONAL LIGHTING

QIAYA Selfie Light Ring

Desktop/laptop/tablet/phone mountable
\$13



Lume Cube Lighting Kit

Desktop/laptop/tablet/phone mountable
\$80



LitraTorch™ 2.0

Multiple mounting options/accessories
\$90



STUDIO LIGHTING

LimoStudio LMS103 Light Kit

incl. stands, diffusers and carrying cases
\$52



ESDDI Soft Box Light Kit

incl. stands, diffusers, cases, & green screen
\$145



Diva Ring Nebula Light Kit

incl. stand, arm, and diffuser
\$250



MOBILE LIGHTING

Aputure Amaran AL-MX

Camera/boom mountable or handheld
\$150



Litra LP1200 LitraPro

Camera/boom mountable or handheld
\$220



Diva Ring Light Nebula

Boom mountable or handheld
\$250





MOBILE DEVICE VIDEO

Many of the current smart devices have incredible video cameras on board. Here are a few helpful tools to round out your mobile device video rig.

LENS ATTACHEMENTS

Catch different shots by adding wide angle, fisheye, telephoto or macro lenses to your device.

Pretmess Lens Kit
Most smartphones \$20
Wide Angle, Fisheye, telephoto and more.



Mikikin Lens Kit
Most smartphones \$30
Wide Angle, Fisheye, telephoto and more.



Xenvo Lens Kit
Most smartphones \$40
Wide angle, macro, LED, case and more.



GIMBAL PHONE STABILIZERS

With a gimbal style stabilizer you'll be sure to catch the smoothest shots for your podcast.

Hohem 3-Axis
Phone Gimbal \$90
You'll have a steady hand with this gimbal/tripod.



Zhiyun Smooth 4
Phone Gimbal \$107
Keep your shot steady with this gimbal/tripod.



DJI osmo Mobile 2
Phone Gimbal \$124
Record stable and smooth shots with this gimbal.



ALL-IN-ONE SOLUTIONS FOR SMARTPHONES

Buy most of the things you'll need in a convenient kit—lights, mics, and stabilizers at the ready.

Handle Grip
by Sevenoak \$75
Light, mic, skid, and stabilizer all-in-one.



Smartphone Rig
by Movo \$120
Gimbal, lights, and microphone all-in-one.



Evolution MOJO
by DreamGrip \$190
Everything you need for a great mobile shoot.



iOS VIDEO SOFTWARE

Edit your videos on the fly with these iOS video editing applications.

 **iMoive**
Video Editor \$0

 **Premiere Rush**
Video Editor \$10/mo

 **Splice**
Video Editor \$10/mo

 **InShot**
Video Editor \$3

ANDROID VIDEO SOFTWARE

Fine-tune your Android shot video podcasts with these mobile editing solutions.

 **InShot**
Video Editor \$3

 **Premiere Rush**
Video Editor \$10/mo

 **YouCut**
Video Editor \$0

 **FilmoraGo**
Video Editor \$8

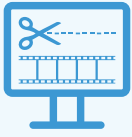

VIDEO EDITING SOFTWARE

With video podcasting comes bloopers, stumbles, odd pauses, loud coworkers - you name it! You'll need video editing capabilities to clean up those rough takes and make quality video podcasts. The below options for video editing software range from simple and easy to use, to in-depth and full featured.

FXhome HitFilm Express

\$0

Powerful but limited option for quick edits and small productions—free on Mac or Windows.



Apple iMovie

\$0

Limited to the Mac and iOS platforms, this is a great free option for quick editing.



Adobe Premiere Pro

\$250 pr/yr

Combine Premiere Pro with Adobe Audition and you have a podcast production dynamo. Mac/Win.



AUDIO EDITING SOFTWARE

You'll need a digital audio workstation (DAW) if you're making audio or video podcasts to help you edit and polish your audio for podcasts. Add a gate to remove ambient noise, compress your voice so all words have the same loudness, add effects like echo or reverb to emphasize specific words, or just add background music to your cast.

Audacity

\$0

Audacity is an easy-to-use, multi-track audio editor and recorder for Windows, Mac OS X, GNU/Linux and other operating systems.

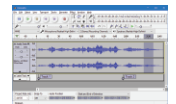

Apple GarageBand

\$0

Make professional-sounding podcasts right away with GarageBand. Just plug in your mic and choose from an array of voiceover presets. This is a great solution for Mac, iPad or iPhone.



Apple Logic Pro X

\$200

GarageBand's big brother packs in everything you'd possibly need for your podcasting efforts. It is easy-to-use and ready to make your podcast audio brilliant.



Adobe Audition

\$300

Adobe Audition is a digital audio workstation from Adobe Systems featuring both a multitrack, non-destructive mix/edit environment and a destructive-approach waveform editing view.



CLEAN UP AND FIX AUDIO

Sometimes recordings have issues. Noise from the background, mic bumping, or distorted phone conversations happen. Even breathing and mouth noises can reduce the quality of your audio. Consider a full featured plugin to fix these issues.

iZotope RX8 Standard

\$300

RX 8 is a complete toolkit for audio cleanup and restoration. Instantly polish recordings, rebalance your audio, remove distracting hum, and surgically fix dialogue using the editor or plug-ins.





HELPFUL AUDIO SOFTWARE

Sometimes the little helpers make all the difference. Here are some apps that may come in handy while creating, capturing, editing, and fine-tuning your podcasts.

VOICE TO TEXT CONVERTERS

Global audiences speak a variety of languages and so may your private podcast listeners. If you decide that you'd like to provide your listeners with a script for your podcast episode, you may want to use a voice-to-text converter. A converter tool will also be beneficial for employees that are unable to listen to podcast content due to a physical disability.

Rev.com

\$1 pr/min of audio

This tool has been used in the past by uStudio customers. Priced at \$1 per audio minute, Rev.com offers quick turnaround time on transcripts any day of the week.

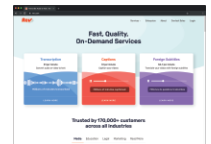

Sonix

\$10 pr/mo plus \$6 pr/hr

Sonix offers a \$10 monthly subscription and \$6 an hour of audio transcription. Sonix is extremely easy and users can download their final transcript in a variety of audio formats.



MISCELLANEOUS SOUNDBOARDS, EDITORS, AND RECORDERS

Rogue Amoeba: Farrago

\$50

Farrago is the Mac's best way to play sound bites, audio effects, and music clips. Podcasters can use Farrago to include musical accompaniment and sound effects during recording.



Trigger

\$545

With its roots in the broadcast world, Trigger has been developed to assist sound engineers in a host of different scenarios. Play sound effects with maximum impact.



Rogue Amoeba: Fission

\$30

Let's say you're producing a simple audio podcast and need a fast way to edit your audio. Fission is streamlined for quick lossless editing and will get your audio ready to roll.



Acon Digital: Acoustica

\$60

Clean up your podcast's audio with this feature-rich editor that will help you find and address any audio issues as well as restore and vitalize your recordings.



Rogue Amoeba: Piezo

\$20

Record audio on your Mac in a snap with Piezo. In seconds, you'll be recording audio from any application or inputs.



Microsoft: Windows Voice Recorder

\$0

Start or resume a paused recording in one click. With this universal app for PC, tablet, and Windows Phone, you can play back, trim, rename, and delete your recordings.





REMOTE RECORDING SOFTWARE

There are plenty of easy ways to record corporate podcasts remotely, whether that's at home or on travel. The below tools are inexpensive and allow for recording remote interviews for your private podcast. And, most record each voice separately to allow for easy post-production editing.

Squadcast.fm

starting at \$9 a month

Record remotely, simplify editing and create engaging podcasts with an intuitive platform that allows you to connect with anyone, anywhere. Offers Audio and Video recording.

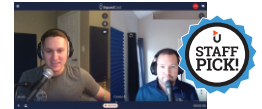

Zencastr

starting at \$0

Record your remote interviews in studio quality, simply send a link and receive a separate track per guest. Currently focuses on Audio, but has a Video beta available.



Riverside.fm

starting at \$19 a month

Record remote video interviews that look & sound amazing. Get studio quality from any guests you're recording. Focuses on video conferencing and interview recordings.

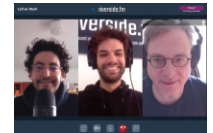

Zoom

starting at \$0

This favorite conferencing application can also be used to record your meetings and interview style podcasts. Supports audio and video.



SETTING UP YOUR EQUIPMENT

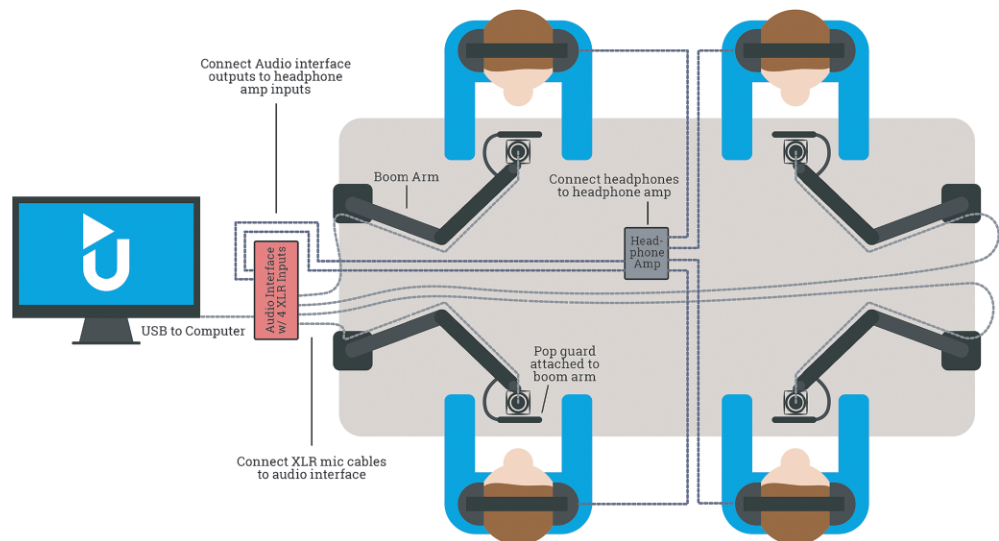

It's important to make sure your microphone is positioned properly within your recording space. Most professionals recommend your microphone is 2-3 fingers away from your mouth and positioned at a slight angle. This is so your microphone doesn't receive the full thump of your consonants but still picks up the volume of your voice. Always make sure to test your equipment before recording to make sure you are comfortable using it and everything is working properly.



RECORDING ENVIRONMENT

You don't need to be sitting in a professional recording studio to record a quality sounding podcast. Many of our clients conduct remote interviews or solo-casts at home or in their small corporate office. Regardless, it's best if your recording environment is comfortable so that you can speak your best. You also want this space to be inviting and pleasant for any in-person guests who are recording with you.

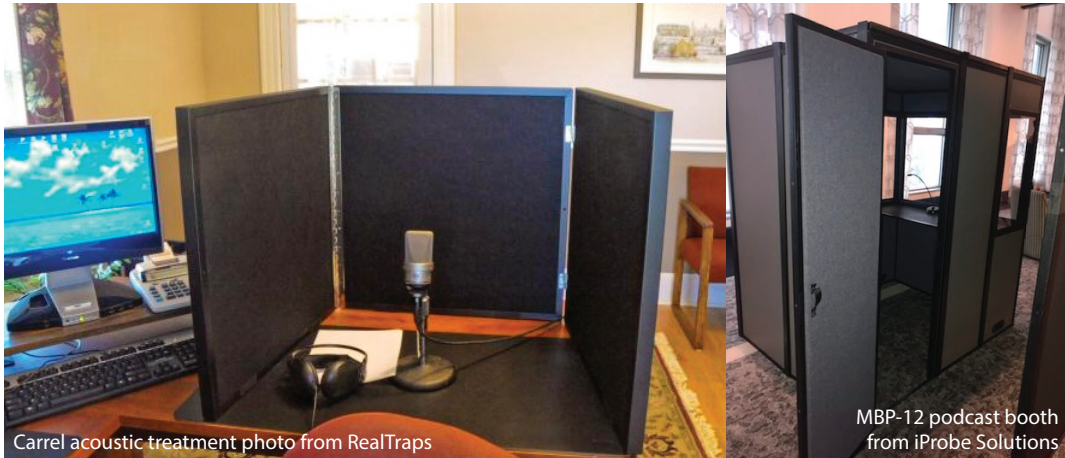

Carrel acoustic treatment photo from RealTraps

MBP-12 podcast booth from iProbe Solutions



Studio 5 photo from Gimlet Media

In many cases, the smaller the environment, the better. In fact, many podcasters recommend sitting in a closet if you are recording from home. It's important to pick a space that has limited external and internal noises which could include air conditioning or neighbors outside. A small room with soft surfaces should help to eliminate echo or reverb. Although a blanket over your head and microphone may sound ridiculous, it is an easy and cheap way to dampen extra noise. And if you are needing additional soundproof help, foam and sound shields can help those vocals to sound even more clear.

[See our Sound Treatment page of this guide for soundproofing ideas](#)



RECORDING YOUR PODCAST

When it comes time to put your gear to work, try to pace yourself when recording. This can help minimize any mistakes and filler words that would need to be cut out in post-production. Practicing out loud can also help you get used to the sound of your voice.

Especially if you are hosting an interview podcast, it is important to stay engaged and listen to your guest, rather than just reading straight from a script. Forbes' Woman to Watch and Glambition Radio Host, Ali Brown, spoke with us regarding the importance of being a good listener.

The biggest compliment I get is being told, "you are such a good interviewer." I ask them why, and they say, "you actually listen." Have you ever listened to an interview where the guest gives an amazing answer, and the interviewer just goes: "okay thanks, question number 2." It happens all the time, and it makes the interview sound terrible because it's not a natural conversation. Listen to how your guest responds and take the conversation from there because that's where the best show content comes from. This also makes your interviewee feel better because it doesn't seem like you're disregarding their words when you're able to customize the questions to fit the flow of the conversation. —Ali Brown

Listen to the full interview...



At the end of the day, it is important to relax and have fun. With the right gear, preparation, and some confidence your podcast will be sounding great in no time.



EDITING YOUR PODCAST

Editing your podcast can be a scary task—but it doesn't have to be. Although learning a new skill is always valuable, there are many third-party production services, like Resonate Recordings, that can inexpensively edit your podcast.

EDITING AUDIO PODCASTS

Almost any audio editor will work great for simply cutting out and trimming audio. Audacity is free and beginner-friendly. Audio Plugins can help balance your signal and remove noise, pops and clicks. It's best to capture audio without any noise artifacts but sometimes that can't be helped. [See our Audio Editing Software section for software recommendations.](#)

Example Audio Editing Process

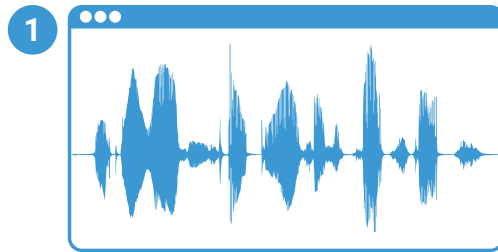

1 Open or import the recorded audio files and give the material a listen

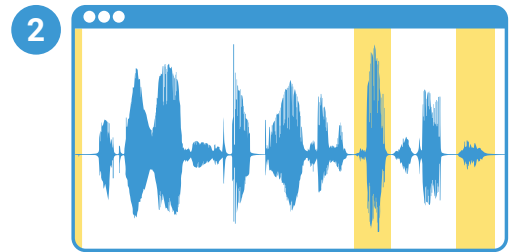

2 Delete unwanted dialog and sounds

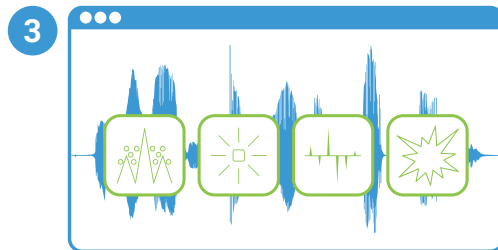

3 Option: use a filter plugin to remove hiss, clicks, crackles, and plosives.

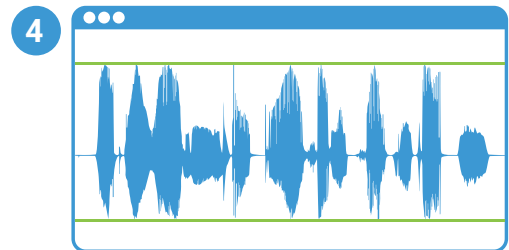

4 Option: Use a compressor and limiter plugin to even out dialog volume

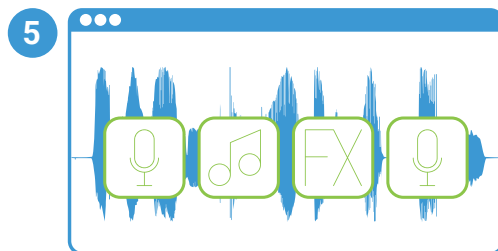

5 Option: Add any intro and outro theme music or sound effects

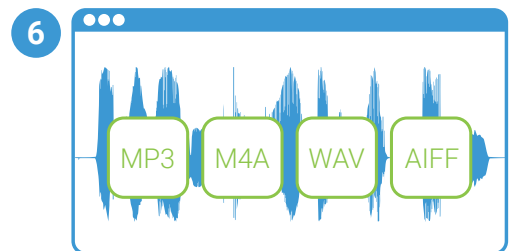

6 Export your finished podcast to upload into uStudio



EDITING VIDEO PODCASTS

A video podcast can make your content even more engaging and luckily it doesn't add too much work to your existing editing workflow. [See our Video Editing Software section of this guide for software recommendations.](#)

Example Video Editing Process

Most video editing software have a common layout and functionality. Reference your video editors manual to understand how to do the following editing process in your software of choice:

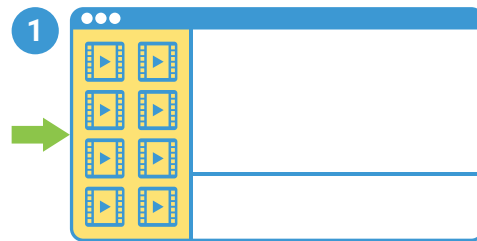

1 Create a new project in your video editor and import your podcast video and graphic assets to the media section.

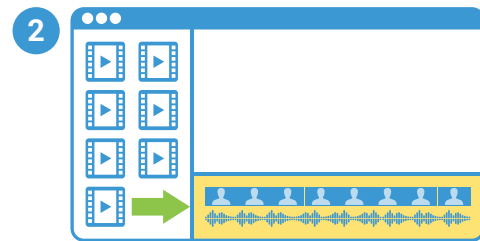

2 Drag and drop your podcast video to the timeline editor.

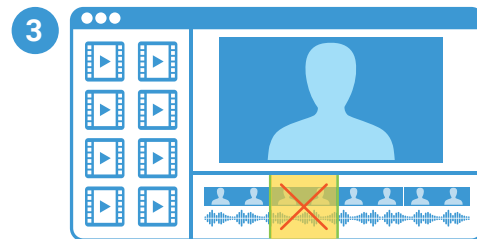

3 Use the cut or scissor tool to remove any mistakes or sections not needed.

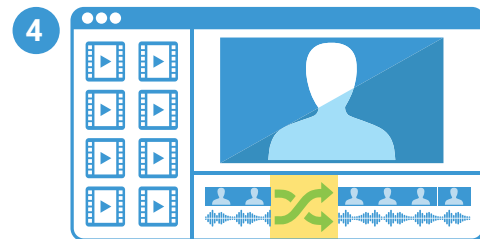

4 *Option:* Use transitions to crossfade or dissolve cuts together.



5 *Option:* Add opening titles and other graphics to your video.

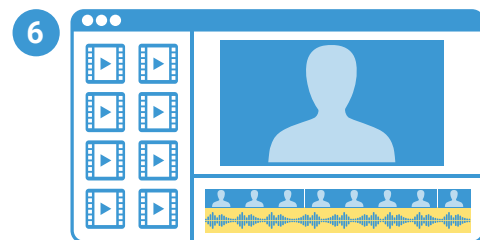

6 *Option:* Use the video editor's built-in audio tools to refine your audio or export the final audio for editing in an audio editor as noted in the Audio Editing section.

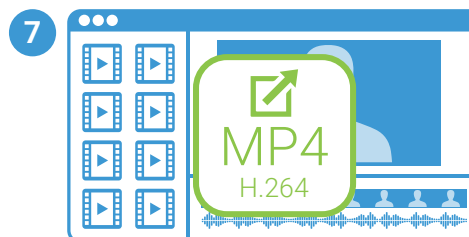

7 Export your final timeline to a media file and upload to uStudio. MP4 using the H.264 codec at 16:9 ratio is recommended.

Modernize the way your business communicates. uStudio’s private podcast solutions allows businesses to deliver corporate audio and video content securely to any device in a modern, mobile-first experience. Our customers are reinventing employee, customer & partner experiences using uStudio’s marketing-leading tools for podcasting and complete media management. uStudio’s secure mobile and desktop products are purpose-built for enterprise use cases, helping business leaders reach increasingly remote and hard-to-engage employees with 5x the effectiveness of traditional channels. Our patented media platform delivers turnkey solutions for everything from town hall meetings to more effective sales training and customer success programs. This is why market leaders like Nike, Universal Music, Astellas, Facebook, Dell and Kohl’s leverage uStudio’s media solutions for speed, scale and competitive advantage.

Learn more and request a free personalized demo at <https://ustudio.com>

Media Solutions for Business

Deliver corporate audio and video content securely to any device in a modern, mobile-first experience

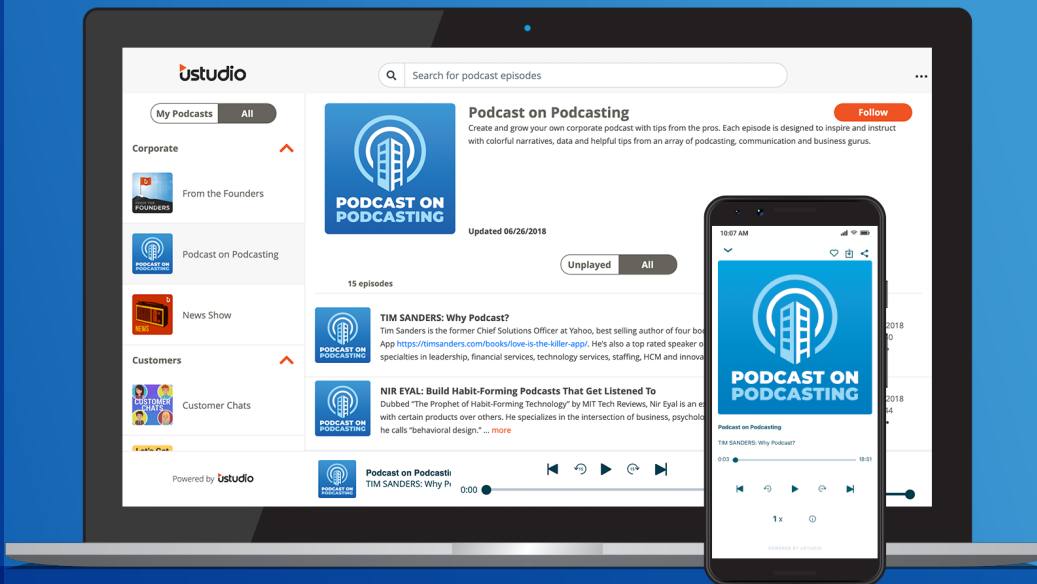

- ✓ Web & Mobile Apps
- ✓ Live & On Demand
- ✓ More Convenient
- ✓ Private & Secure
- ✓ High Engagement

GET STARTED TODAY!